



K2025

High Performance Liquid Chromatography

About Wooking Instruments

Shandong Wooking Instruments Co. Ltd is affiliated with Hanon Advanced Technology Group Co., Ltd. The Wooking team devotes itself to the business of scientific instruments and is committed to the research and development of chromatography and spectroscopy technologies.

The Wooking K2025 is designed to be reliable, precise, ease of use, and compliant. Wooking is aiming to provide a better user experience and become the world's leading provider of scientific instruments and services.



Wookinglab Workstation



K2025 High Performance Liquid Chromatography

Wooking K2025

High Performance Liquid Chromatography

K2025 P1/P2/P4 Pump -----
(Isocratic/Binary/Quaternary)

K2025AS Autosampler -----

K2025CO Column Oven -----

K2025UVD/DAD/FLD/RID/ELSD Detector -----



Reliability

With the reliable design and high-quality components, K2025 passes the reliability test performed by authority, ensuring the long-term running in optimum condition.

Precision

The precision and accuracy of the results are guaranteed with our unique pumping and sampling technology, high sensitivity detector, and powerful data processing software.

Wookinglab Workstation

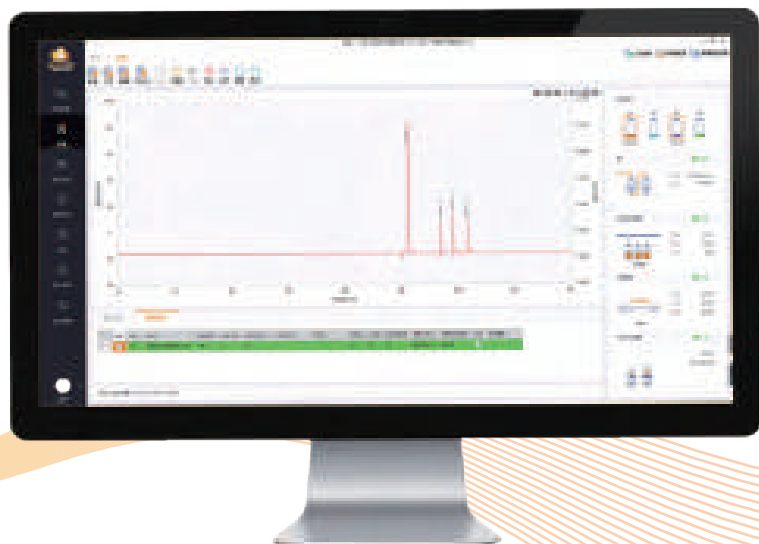

Ease of use

The operation is more convenient and efficient with a variety of user-friendly designs in Wookinglab

Compliance

Wookinglab fully complies with FDA 21 CFR Part 11 with database mode and data traceability.

K2025 P1/P2/P4 Pump



Specifications:

Flow rate range	0.001mL/min~10.000mL/min
Pump type	Isocratic(P1), Binary(P2), Quaternary(P4)
Maximum pressure	62MPa
Plunger rinsing	Supported



P2 Binary pump



P4 Quaternary pump

Precision

Excellent repeatability

The precise gradient change and retention time are guaranteed with the reciprocating tandem plunger pump and pressure dynamic suppression algorithm. The repeatability of retention time is less than 0.2%.

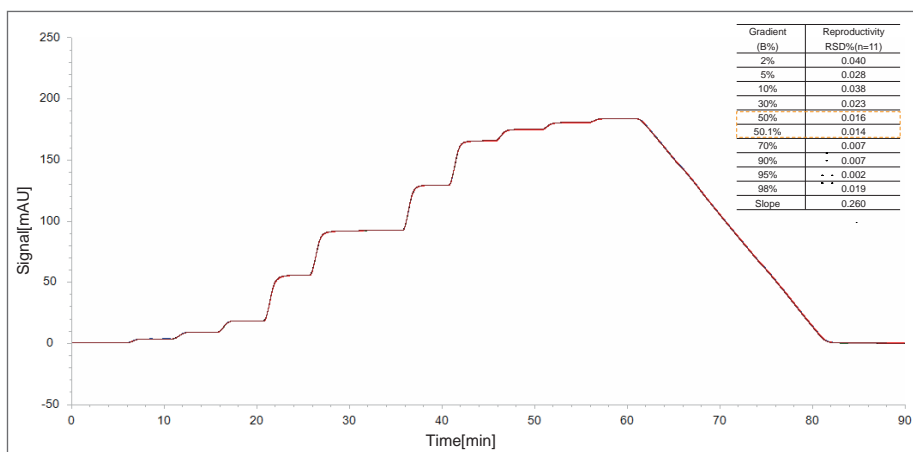

Gradient test

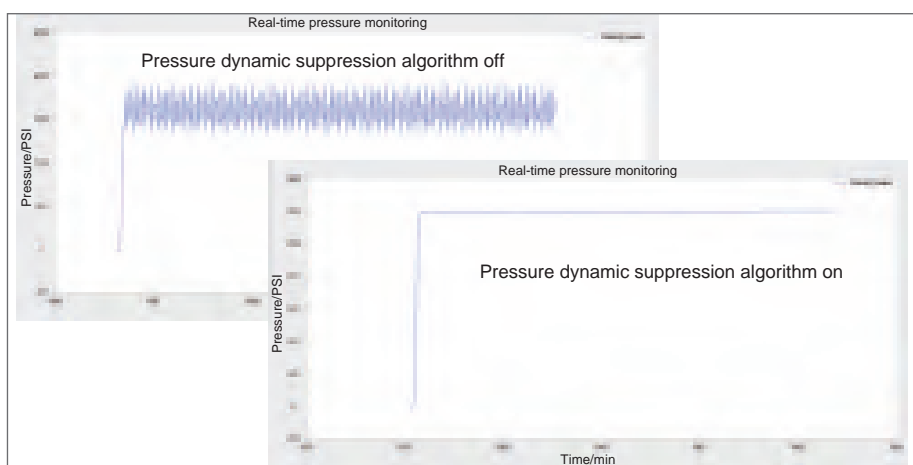

Pressure fluctuation test

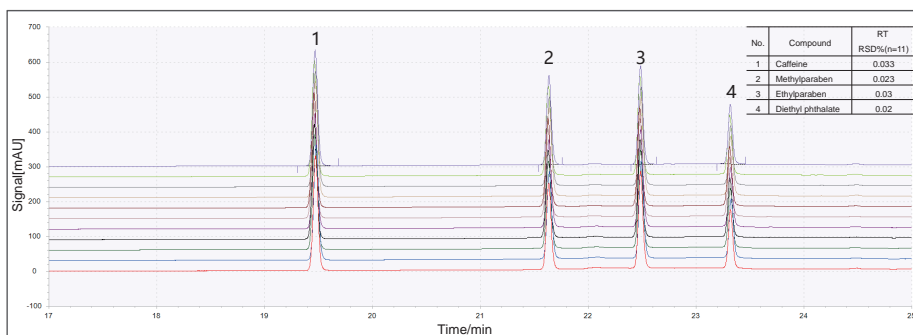

Retention time repeatability test

Reliability

The reliable design makes service life longer

Material

The cam is integrally processed from high-hardness alloy steel and combined with high-frequency heat treatment technology, which makes the surface of the cam is more wear-resistant (the hardness is above 55HRC), and the service life is longer.

Power

The high-power customized motor, Japanese NSK bearings, and independent air duct make the power and life even better.

Gearing

Self-lubricating and wear-resistant materials imported from Germany are used for the piston drive mechanism. Also, the inner wall rifling design prevents the piston from accidentally locking, making the gearing more reliable.

Plunger

The patented suspended floating plunger(Patent Number: ZL 2020 2 1896102.3) can adapt to the working conditions automatically, which is convenient for disassembly and prevents the eccentric wear of the sealing ring effectively. With the special sealing structure and the automatic cleaning of the plunger, the pump seal is more reliable.

Ease of use

Equipped with an online automatic rinsing mechanism

When the pump is working, the rinsing pump is automatically turned on and runs periodically, which can effectively prevent the crystallization of buffer salts and the growth of microorganisms, and prolong the service life of the plunger and plunger sealing.

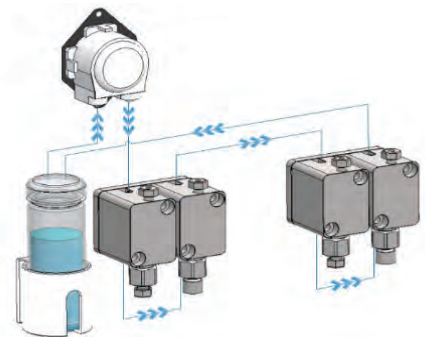

Easy to purge

Both the workstation and the instrument panel are equipped with a purging function, making it easier to purge.

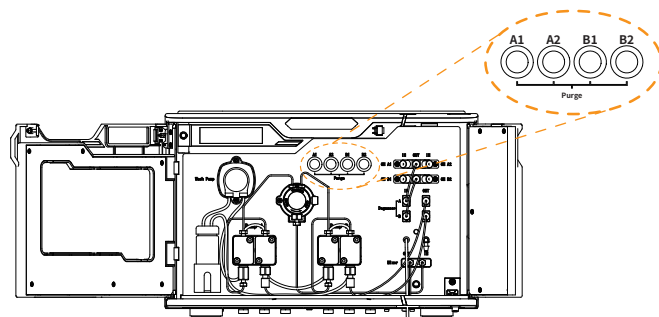

Intelligent solvent switching to improve efficiency

Equipped with a 4-channel solvent selection valve for binary pump. The solvent can be automatically switched according to the method.

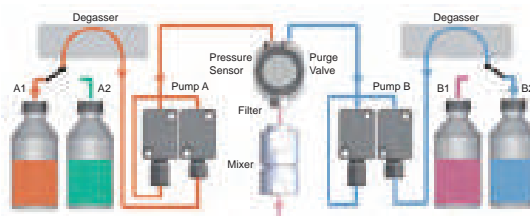

Independent 4-channel gradient proportioning valve, easy for maintenance

The gradient proportioning valve of the quaternary pump adopts a 4-channel independent design. The intelligent monitoring and diagnosis can realize real-time monitoring and independent replacement of each channel, the whole design can reduce maintenance costs effectively.

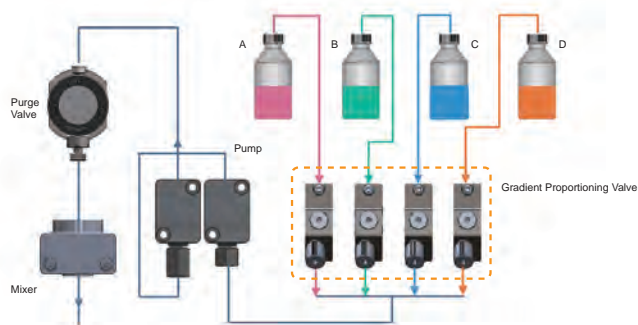

K2025AS Autosampler



Specifications:

Sample capacity	108, 2mL(96&384 well plates)
Injection range	0-100 μ L
Injection mode	Low-loss, microliter carrying, full-loop
Injection time	Minimum to 5s
Carryover	0.003%
Degassing unit	Online degassing(optional)
Temperature control	4-40 $^{\circ}$ C(optional)

Precision

Precise injection volume

The K2025 autosampler adopts a patented integrated constant pressure needle ([Patent Number: ZL 2020 2 1159205.1](#)) and a precise syringe pump, which ensures accurate injection volume and excellent linearity, making the results more precise and accurate.

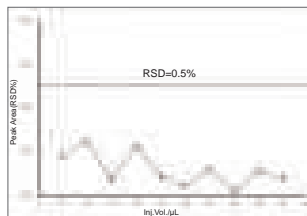

Repeatability test

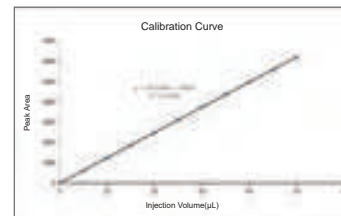

Linearity test

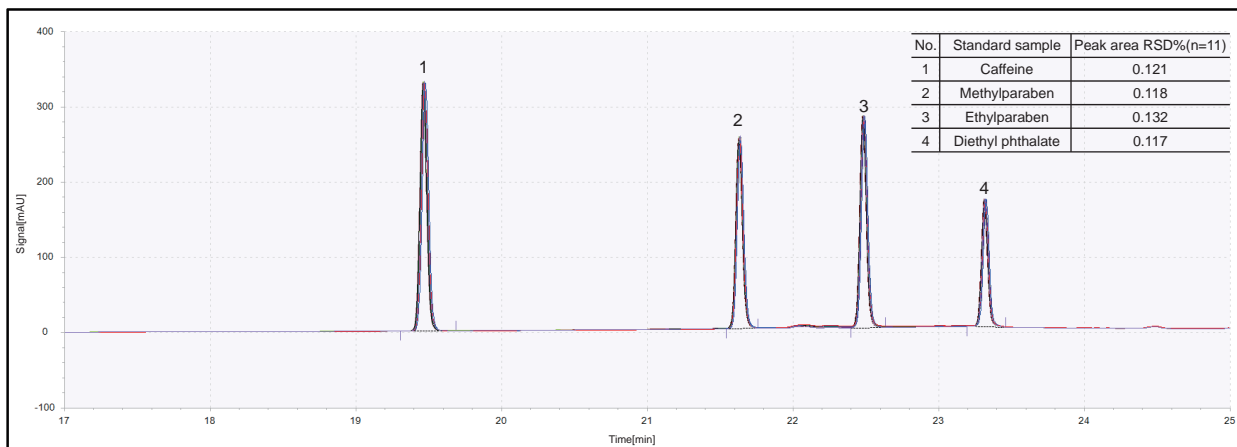

Low carryover to make results more accurate

The sampling needle is highly polished for the outer surface and passivated for the inner surface, which can effectively reduce the sample residue. The carryover is much lower when needle washing of the outer and inner surfaces are performed.

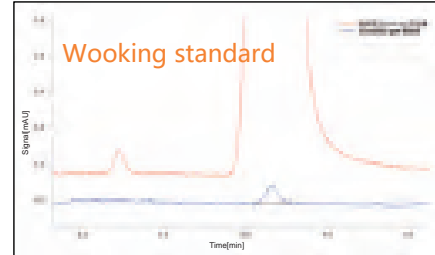
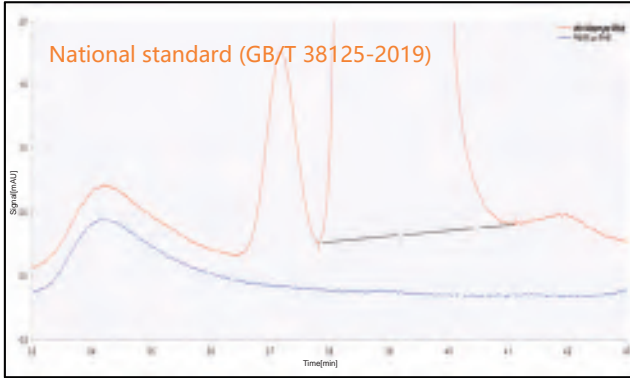

Sample	Peak area	Carryover
Caffeine 3000ppm	Overload	
Blank sample after needle washing	0.559	$\frac{0.559}{3286.287 \times 20} \times 100\% = 0.00085\%$
Caffeine 150ppm	3286.287	

Reliability

Design of needle

With our integrated constant pressure sampling needle (Patent Number: ZL 2020 2 1159205.1), the air pressure inside and outside the sample bottle can be balanced during sampling; the injection port is set on the sidewall to prevent bottle pad debris from clogging the needle during puncture.



Design of degassing unit of washing liquid

The built-in autosampler degassing unit can be used for degassing of washing liquid, avoiding interference caused by air bubbles

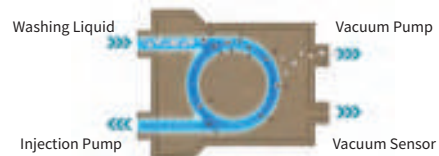

Design of mechanical arm

The ball monorail design of the mechanical arm effectively prevents the arm from locking during moving. The operation is more stable when combined with the motor closed-loop control and out-of-step protection algorithm.



Design of self-compensation injection pump

The maintenance-free self-lubricating guide device and self-compensating sliding screw are used for real-time compensation of the slight wear, and it has excellent motion accuracy and is more durable.



Ease of use

- Patented preloaded sample injection mode (Patent Number: ZL 2020 2 2977790.2), the injection time can be shortened to 5s, which greatly improves the efficiency.

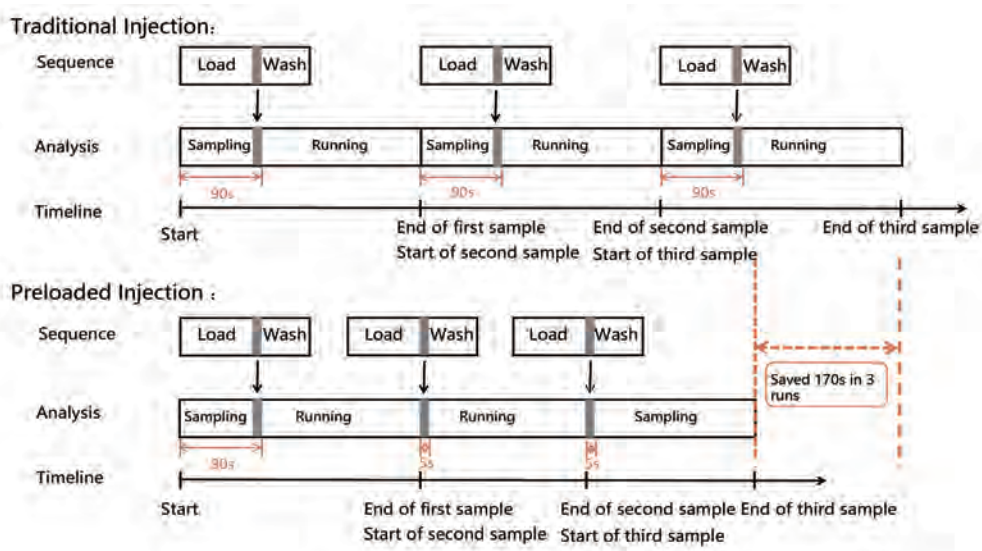

- A variety of injection modes combined with sample temperature control technology to satisfy different detection needs such as rare and unstable samples
- The dehumidification function is optionally equipped to avoid the generation of condensed water, effectively prevent the sample from being diluted, and ensure accurate results
- The maintenance is more convenient and efficient with the in-front injection valve.

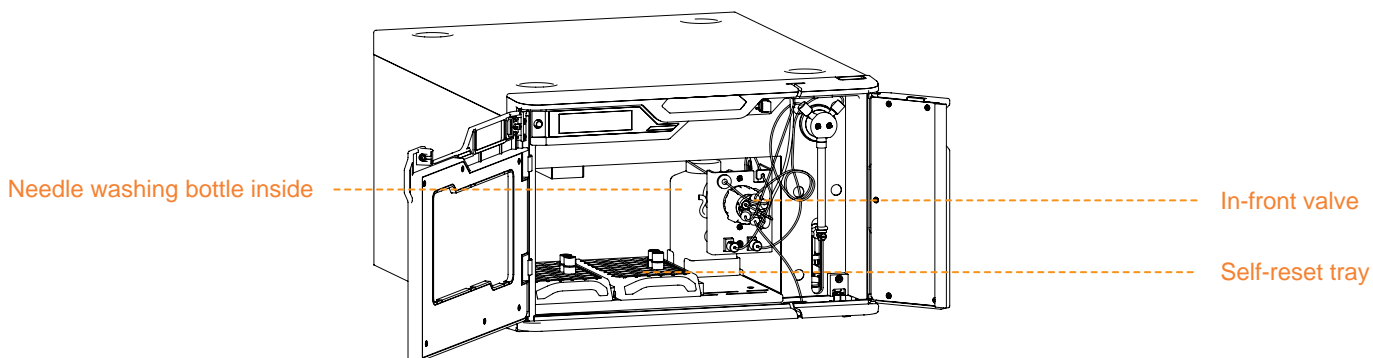

K2025CO Column Oven



Specifications:

Operating principle	Peltier element and fan-based forced air
Temperature range	5 °C above ambient to 85°C 10 °C below ambient to 85°C

Precision

Precise temperature control ensures good separation and repeatability

Using fuzzy PID intelligent temperature control algorithm, fan-based air circulation, and multiple insulation layer design, the column temperature is more accurate, stable, and uniform, the temperature stability is $\pm 0.1^{\circ}\text{C}$, and the temperature for each analysis are constant and consistent.

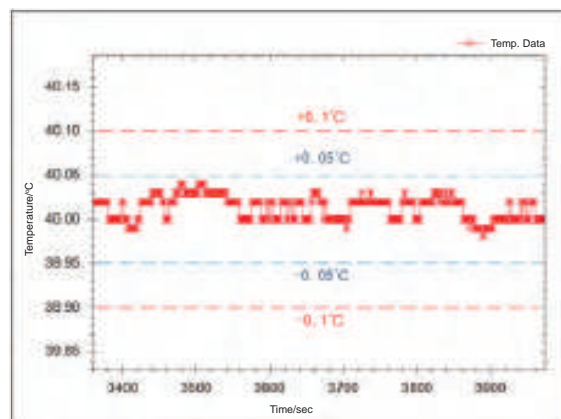
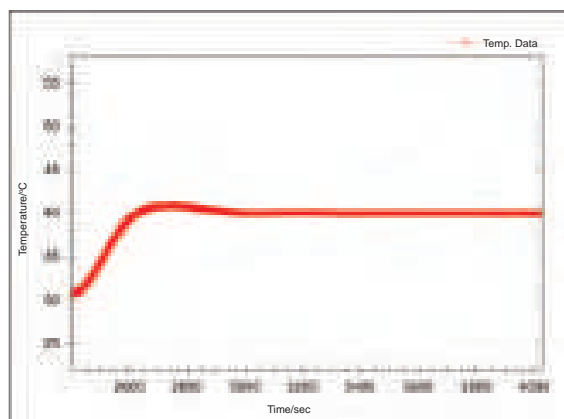

Reliability

Triple protection, more safe to use

Real-time liquid leak protection, intelligent monitoring of Peltier and cavity temperature, over-temperature power-off protection, triple safety protection designs, effectively prevents accidental liquid leakage and dangers caused by over-heating.

K2025UVD UV-Vis Detector



Specifications:

Light source	Deuterium(transmission type) and Tungsten lamp
Wavelength range	190-800nm
Wavelength accuracy	+/- 1nm
Wavelength precision	+/- 0.1nm
Linearity	>2.5AU
Wavelength calibration	Mercury lamp

Precision

Low LOD

The high-throughput optical path, reference subtraction algorithm, and ultra-precise signal acquisition circuit ensure the detector's excellent sensitivity.

Sample: 1.0×10^{-7} g/mL Naphthalene
 Column: C18, 4.6×250mm, 5μm
 Mobile phase: 95:5=Methanol: Water
 Flow rate: 1.0mL/min
 Injection Volume: 20 μL
 Wavelength: 254nm

$$\text{LOD } C_{\min} = \frac{3H_N \times c}{H} = \frac{3 \times 0.005 \times 1.0 \times 10^{-7}}{0.609} = 2.4 \times 10^{-9} \text{ g/mL}$$

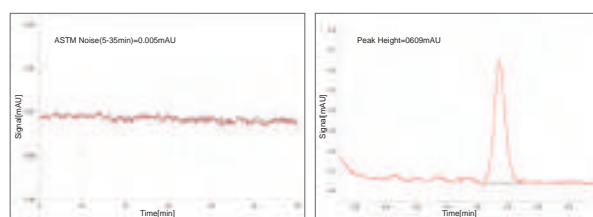

Wide linearity

The UVD covers a wide linear range of 2.5AU, making it easier to analyze high concentration samples

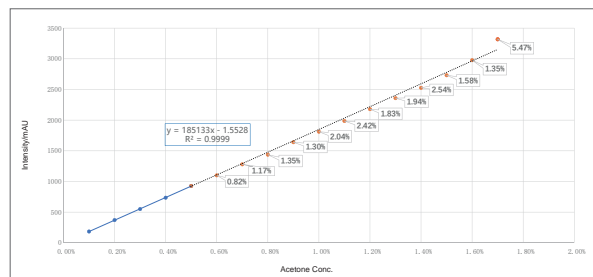

Reliability

The patented transmission type deuterium lamp and static light path (Patent Number: ZL 2020 2 0832429.8) allow the light source switching without moving of lamp, which is more reliable.

With the patented design of the optical unit (Patent Number: ZL 2020 2 0832429.8) and the light source module, the service life is much longer.



Ease of use

Full-band spectral scanning

A full-band spectral scanning can be performed to easily find the optimal absorption wavelength of the target analyte.

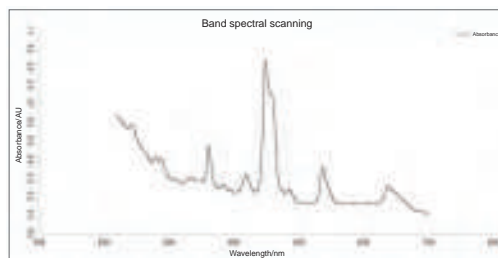

Wavelength time programming

Wavelength can be set for different analytes during different periods, to accomplish the high-sensitivity analysis of complex samples

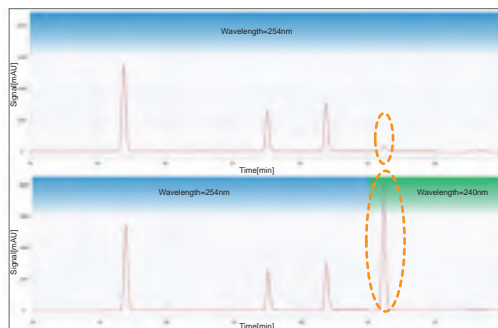

Maintenance and safety

Built-in mercury lamp for wavelength calibration

Over-temperature protection of light source

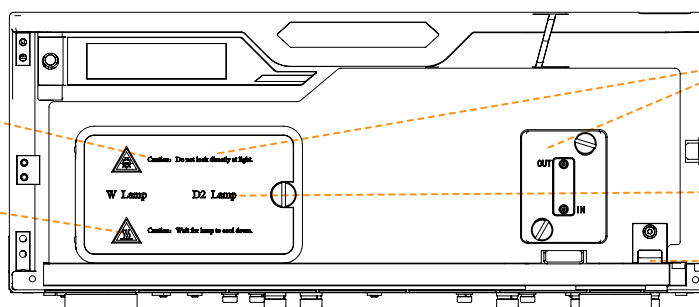

In-front light source and flow cell

Automatic tracking of light energy

Liquid leak sensor

K2025DAD Diode Array Detector



Specifications:

Light source	Deuterium (transmission type) & Tungsten lamp
Wavelength range	190–800nm
Slit width	1nm, 2nm, 4nm, 8nm
Wavelength accuracy	+/- 1nm
Wavelength precision	+/- 0.1nm
Linearity	> 2.0 AU
Wavelength calibration	Holmium glass

Precision

Spectral similarity alignment and peak purity determination are performed for precise qualitative and quantitative analysis

DAD provides full-spectrum information. The compounds can be identified by similarity comparison in the spectral database. Peak purity determination can be performed in the workstation.

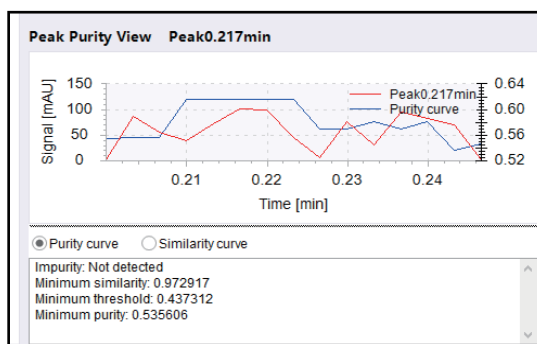
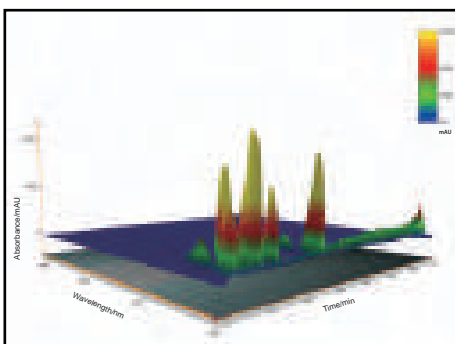

High sensitivity—Close to UV Detector

High sensitivity mode can be performed for low concentration samples, the signal-to-noise ratio of DAD can be reached to the same level of UVD.

Sample: 1.0×10^{-7} g/mL naphthalene standard solution
 Column: C18, 4.6*250mm, 5µm
 Mobile phase: 95% methanol +5% water
 Flowrate: 1.0mL/min
 Injection volume: 20µL
 Wavelength: 254nm

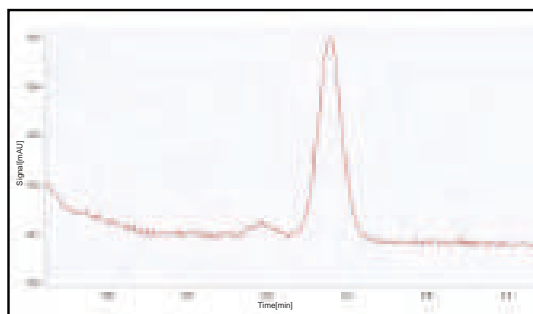

Achieving more accurate inspection data by high-resolution spectra.

When compound detection is performed in high-resolution mode, a finer spectral map can be output for better analysis of complex samples.

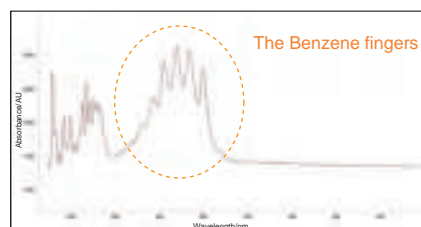

Ease of use

Supports 12-channel real-time data collection

Significantly enhance the analysis efficiency by:

- Up to 12 wavelengths can be set for real-time detection;
- Real-time analysis at a high sampling rate up to 150 Hz;
- Full-spectrum detection.

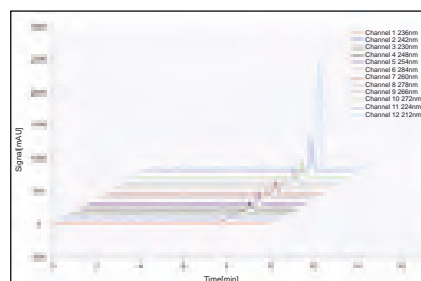

Rapid spectral scanning for multiple use

When configured with a cuvette holder, samples can be loaded directly into the cuvette for rapid spectral scanning, to realizing UV spectrophotometer functionality.

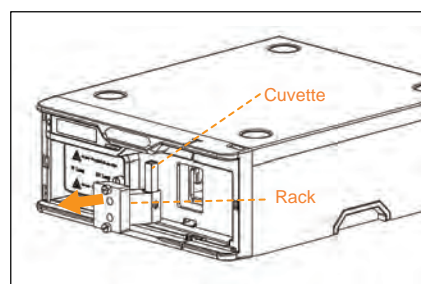

K2025 Other Detectors

By using high-resolution K2025ATD, the detector can be equipped with versatile detectors such as Fluorescence Detector(FLD), Refractive Index Detector(RID), Evaporative Light Scattering Detector(ELSD), and CAD to meet the detection of different compounds.



K2025ATD

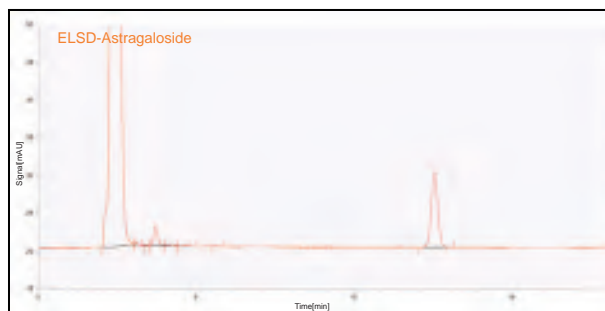
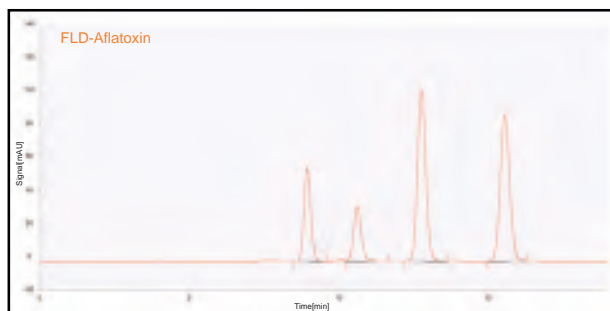

Wookinglab Workstation

User-friendly

Ease of use

The workstation interface is flat designed to quickly complete method development, data acquisition, data processing, report editing and printing, etc..

- The left side of the interface is the navigation area, on which functional modules can be quickly found, such as project management, spectrogram acquisition, and integral processing
- The top of the acquisition interface is a common ribbon that allows you to edit and run methods and sequences without the need for multi-level menus
- The right side of the acquisition interface is the status monitoring area, which dynamically displays the real-time status of the instrument

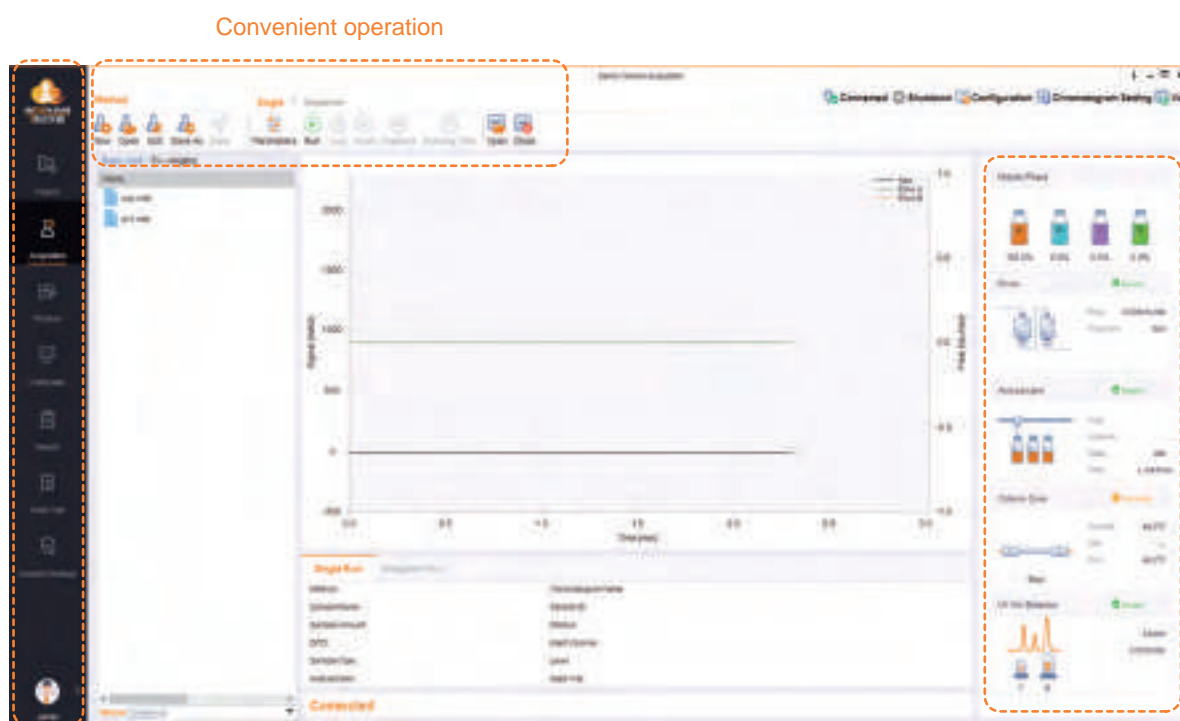

Organized navigation

Clear status monitoring

User-friendly design

- The workstation has built-in the 2020 edition of the "Chinese Pharmacopoeia" and "Chinese Veterinary Pharmacopoeia" standard method library, which can be directly retrieved and recalled to improve work efficiency
- The workstation provides intelligent diagnostics and maintenance reminders for the instrument

Precision

Powerful data-processing capability

Up to 25 integration events and 3 quantitative calculation methods (external standard method, internal standard method, and normalization method) for complex data.

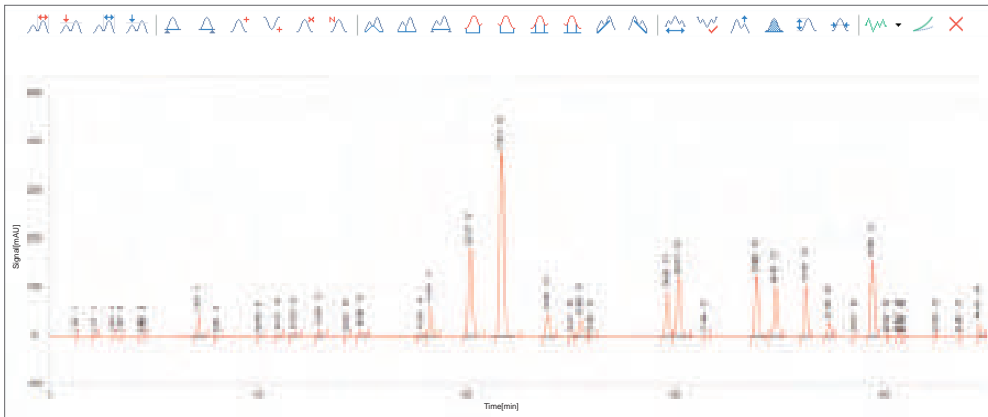

Compliance

Database storage

With the professional database system, the encryption of original files and security of raw data can be guaranteed.

Backup and restore

Backup and restore of data can be easily performed in the workstation, which is convenient for users.

Multi-level user system

Supports customized multi-level system for access to data, ensuring the effectiveness of the system.

Traceability

The workstation complies with FDA 21 CFR Part 11, with complete records and integrity traceability.

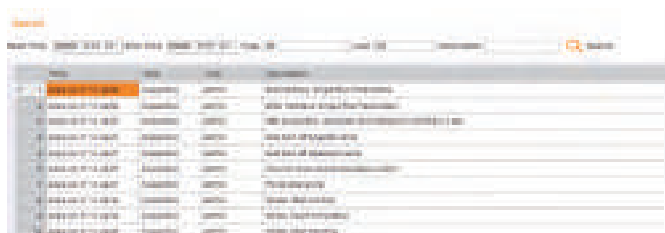
A screenshot of a software interface showing a data table. The table has several columns, including what appears to be a list of items or samples, and their corresponding data values. The interface includes a search bar at the top and a list of items below the table.

Applications

Pharmaceutical Industry

Analysis of ginsenosides of Rg1, Re, Rb1

※ Referred to 2020 Chinese Pharmacopoeia

- Column: C18 4.6×250 mm, 5µm
- Mobile phase: A: ACN B: 0.1% phosphoric acid/water
- Temperature: 40°C
- Injection Volume: 10µL
- Flow rate: 1.0 mL/min
- Wavelength: 203nm

Gradient		
Time/min	A%	B%
0	19	81
25	20	80
60	40	60
90	55	45
100	60	40
110	19	81
120	19	81

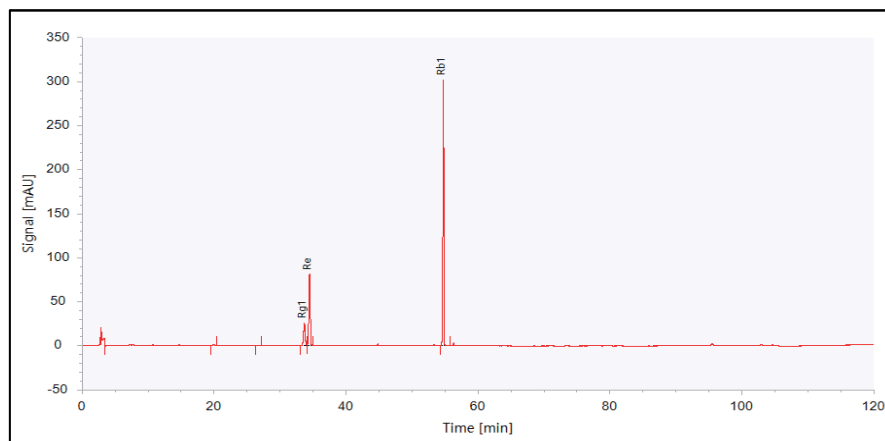

Analysis of specific spectrum of *Lonicera japonica* dispensing granules

※ Referred to YBZ-PFKL-2021073

- Column: C18 4.6×250 mm, 5µm
- Mobile phase: A: ACN B: 0.4% phosphoric acid/water
- Temperature: 35°C
- Injection Volume: 15µL
- Flow rate: 1.0 mL/min
- Wavelength: 350nm

Gradient		
Time/min	A%	B%
0	10	90
15	10	90
20	15	85
50	20	80
55	30	70
60	10	90

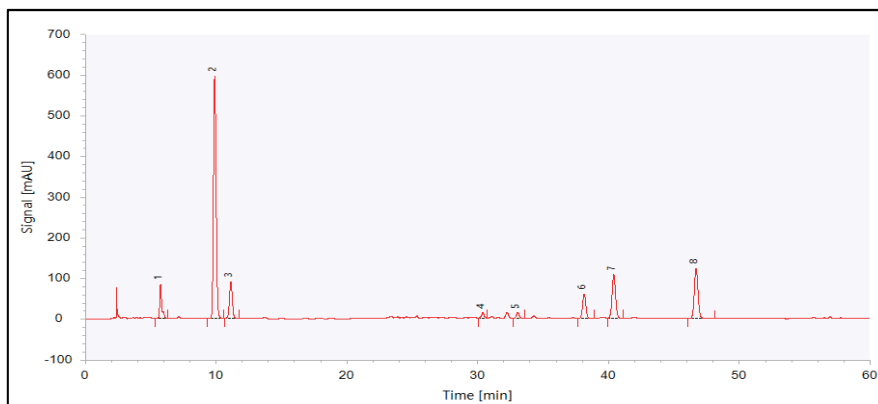

Environmental Industry

Analysis of 16 polycyclic aromatic hydrocarbons in water

※ Referred to HJ 478-2009

- Column: C18 4.6×250 mm, 5μm
- Mobile phase: A: ACN B: Water
- Temperature: 30°C
- Injection Volume: 10μL
- Flow rate: 1.2 mL/min
- Wavelength: time program

Gradient			Wavelength time program		
Time/min	A%	B%	Start time/min	Hold time/min	Wav./nm
0	60	40	0	9.0	220
15	60	40	9.0	4.5	254
20	100	0	13.5	5.5	220
31	100	0	19.0	3.5	290
32	60	40	22.5	4.0	254
45	60	40	26.5	0.5	290
			27.0	18.0	220

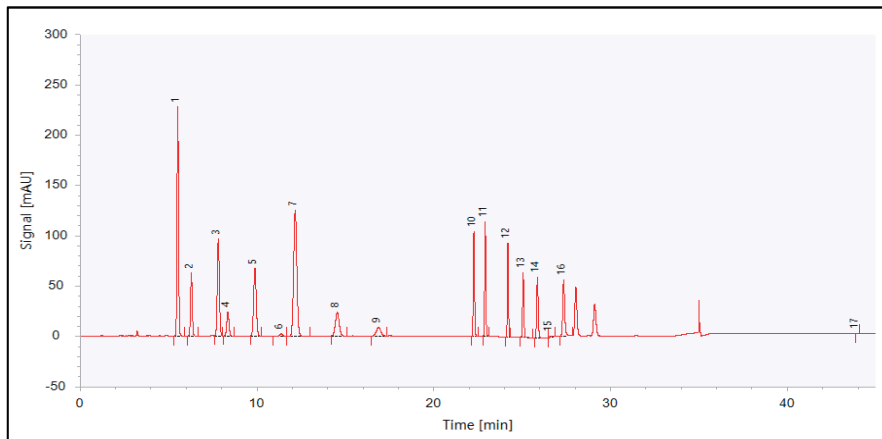

Analysis of aldehyde and ketone compounds in waste gas from stationary pollution sources

※ Referred to HJ 1153-2020

- Column: C18 4.6×250 mm, 5μm
- Mobile phase: A: Methanol B: ACN C: Water
- Temperature: 35°C
- Injection Volume: 10μL
- Flow rate: 1.0 mL/min
- Wavelength: time program

Gradient			
Time/min	A%	B%	C%
0	45	20	35
6	70	0	30
24	80	0	20
33	45	35	20
33.1	45	20	35
42	45	20	35

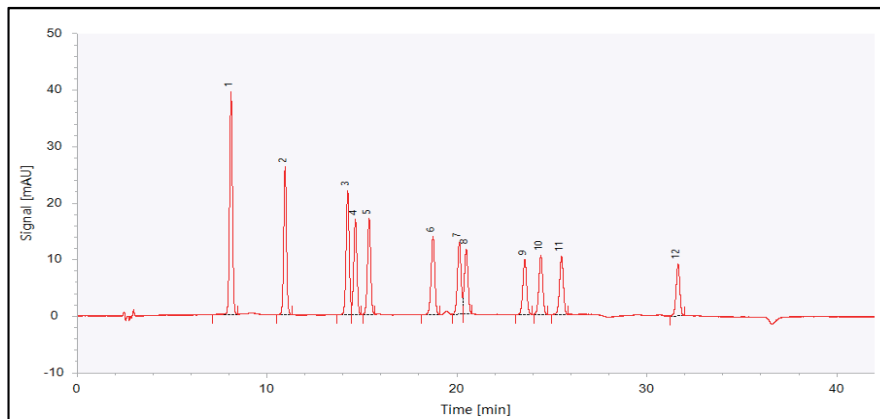

Veterinary Drugs

Analysis of the veterinary drug Enrofloxacin

※ Referred to the 2020 Chinese Veterinary Pharmacopoeia

- Column: C18 column (4.6×250mm, 5μm)
- Mobile phase: 0.025% mol/L aqueous solution of phosphate (pH to 3.3 with triethylamine) + acetonitrile (83+17)
- Temperature: 25 °C
- Injection volume: 10 μL
- Flow rate: 1.0mL/min
- Wavelength: 278 nm

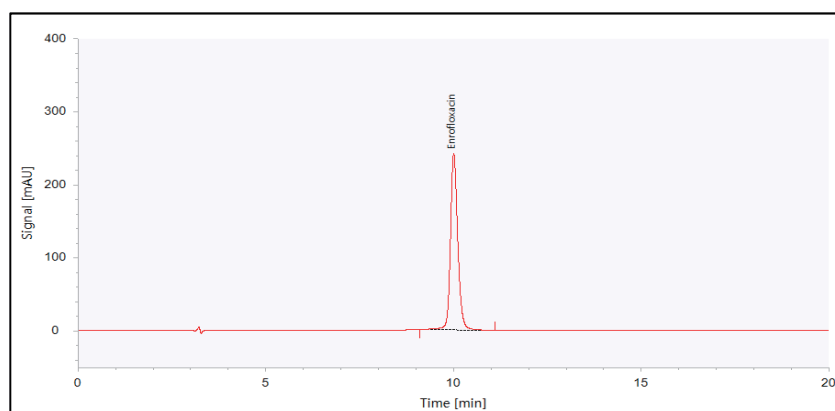

Dairy Products

Dairy immunoglobulin IgG analysis

※ Referred to T/SSFS0002-2021

- Column: BioCore™ SEC-300se column (4.6×250mm, 5μm)
- Mobile phase: 20 mmol/L phosphate solution (pH = 7.0)
- Temperature: 30 °C
- Injection volume: 10 μL
- Flow rate: 0.5mL/min
- Wavelength: 214nm

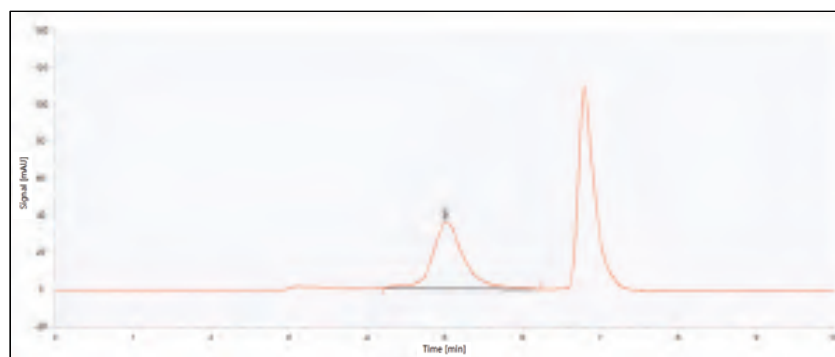

Food

Analysis of sialic acid in bird's nest and its products

※ Referred to GB/T30636-2014

- Column: 300SCX Cation Exchange Column (4.6×250 mm, 5 μm)
- Mobile phase: acetonitrile + 0.1% aqueous phosphate solution (90 + 10)
- Column temperature: 30 °C
- Injection volume: 10 μL
- Flow rate: 1.0mL/min
- Wavelength: 205 nm

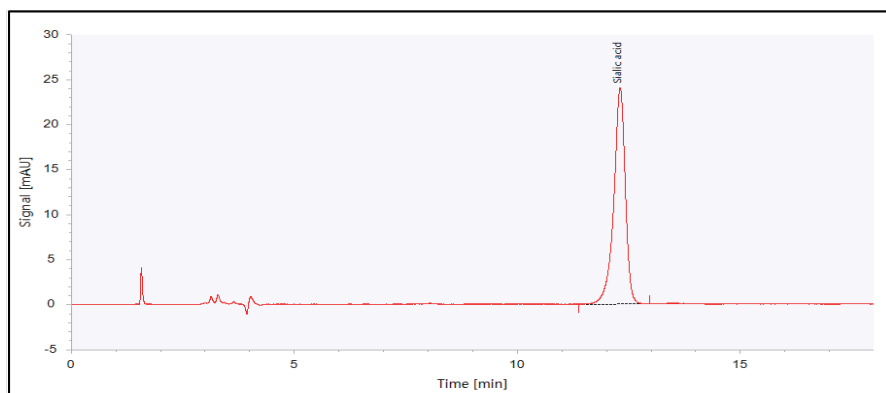

Cosmetics

Analysis of p-phenylenediamine, 2,5-diaminotoluene, and resorcinol in hair dyes

※ Referred to "Cosmetic Safety Technical Specifications"

- Column: C18 column (4.6×250mm, 5μm)
- Mobile phase: Acetonitrile + methanol + 0.02mol/L ammonium acetate buffer (pH 7.5) (2.5 + 2.5 + 95)
- Temperature: 25 °C
- Injection volume: 20 μL
- Flow rate: 1.0mL/min
- Wavelength: 280nm

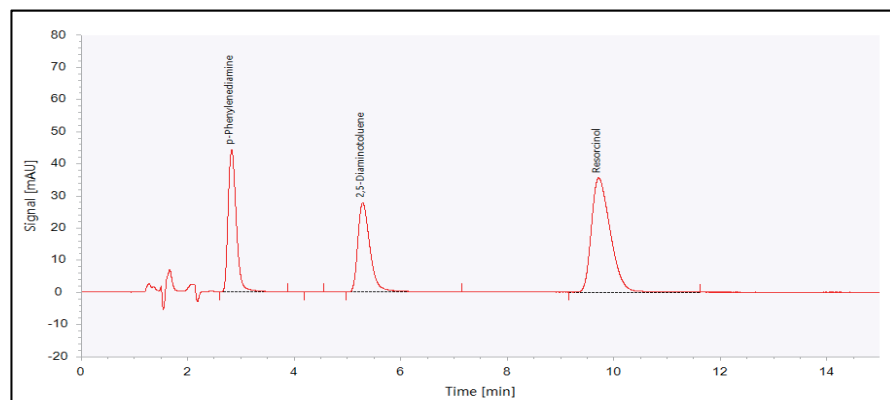

Hanon Group

Hanon Advanced Technology Group Co., Ltd. (Headquarter)

Addr.: 4th Floor, Building 1, A3 Zone, Financial Business Center of Hanyu, Jinan, China 250101

Tel.: +86 531 88874440 Fax: +86 531 88874445

<http://www.hanonlab.com> Email: info@hanon.cc

Shandong Wooking Instruments Co., Ltd.

East of HuaYuan Road, Linyi town, Dezhou City, China

www.wooking.com